

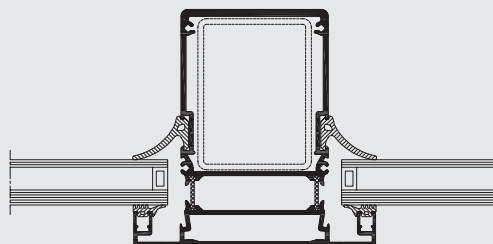

# TR 200

Conservatories

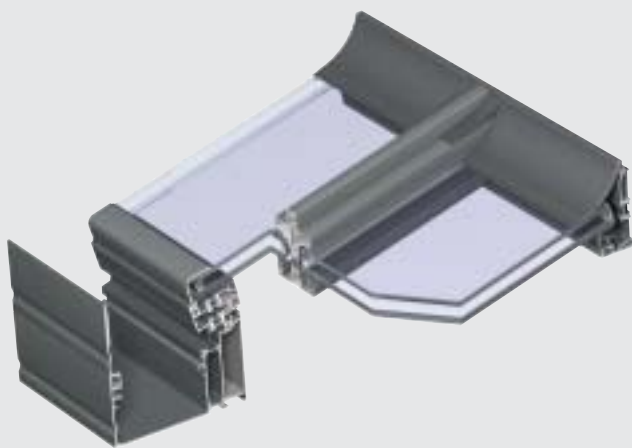

TR 200 is a thermally insulated conservatory system made of insulated aluminium T profiles. The interior of the roof structure, the colour of which can differ from the exterior, can be given an extremely discreet appearance by allowing the T profiles to continue on the outside. The gutters are available in 3 styles: Renaissance, Functional or Ellipse. TR 200 can be combined with all window and door systems as well as sliding systems. The integration of skylights is also possible (electrically-operated if desired).

## TECHNICAL CHARACTERISTICS



Style variants	<b>FUNCTIONAL</b> / <b>RENAISSANCE</b> / <b>ELLIPSE</b>
Overall system depth of rafter	inside: 18 mm outside: 23 - 58 mm
Min. visible width of rafter	70 - 99 - 128 mm
Slope	5° - 45°
Ridge and calley	126° - 180°
Glass thickness	6 - 40 mm
Glazing method	dry glazing with EPDM
Thermal insulation	14 and 18.6 mm fibreglass reinforced polyamide strips + synthetic profile

## PERFORMANCES

### COMFORT

Air tightness, max. test pressure <sup>(1)</sup> EN 1026; EN 12207	1 (150 Pa)		2 (300 Pa)			3 (600 Pa)		4 (600 Pa)			
Water tightness <sup>(2)</sup> EN 1027; EN 12208	1A (0 Pa)	2A (50 Pa)	3A (100 Pa)	4A (150 Pa)	5A (200 Pa)	6A (250 Pa)	7A (300 Pa)	8A (450 Pa)	9A (600 Pa)	E (900 Pa)	
Wind load resistance, max. test pressure <sup>(3)</sup> EN 12211; EN 12210	1 (400 Pa)		2 (800 Pa)		3 (1200 Pa)		4 (1600 Pa)		5 (2000 Pa)		E <sub>xxx</sub> (> 2000 Pa)

This table shows possible classes and values of performances. The values indicated in red are the ones relevant to this system.

- (1) The air tightness test measures the volume of air that would pass through a closed window at a certain air pressure.
- (2) The water tightness testing involves applying a uniform water spray at increasing air pressure until water penetrates the window.
- (3) The wind load resistance is a measure of the profile's structural strength and is tested by applying increasing levels of air pressure to simulate the wind force. There are up to five levels of wind resistance (1 to 5) and three deflection classes (A,B,C). The higher the number, the better the performance.

REYNAERS ALUMINIUM NV/SA • [www.reynaers.com](http://www.reynaers.com) • [info@reynaers.com](mailto:info@reynaers.com)

11/2007 - 0H0.62C2.00 - Publisher Responsible at Law: L. Finé, Oude Liersebaan 266, B-2570 Duffel

