

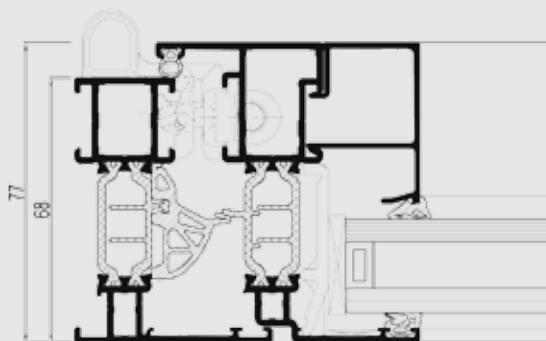

CS 77

Windows & Doors

R
REYNAERS
aluminium

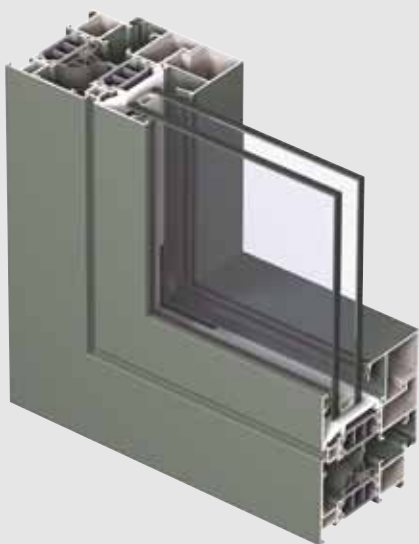

CS 77 is a thermally improved three-chamber system for windows and doors that boasts the optimum combination of safety and comfort. Fibreglass reinforced polyamide strips with ribs and/or hollow chambers guarantee high thermal insulation levels.

The system is available in a variety of aesthetic shapes to match the current architectural trends whilst offering all types of both inward and outward opening windows and doors. A double butt strip between the frame and vent and a lowered drainage ensure superior wind and water tightness.

Different inner and outer colours are possible.

TECHNICAL CHARACTERISTICS



Style variants	FUNCTIONAL	RENAISSANCE	HIDDEN VENT
Min. visible width inward opening window			
Frame	51 mm	51 mm	76 mm
Vent	33 mm	33 mm	not visible
Min. visible width outward opening window			
Frame	17.5 mm	-	-
Vent	76 mm	-	-
Min. visible width inward opening flush door			
Frame	68 mm	-	-
Vent	76 mm	-	-
Min. visible width outward opening flush door			
Frame	42 mm	-	-
Vent	102 mm	-	-
Min. visible width T-profile	76 mm	76 mm	126 mm
Overall system depth window			
Frame	68 mm	77 mm	68 mm
Vent	77 mm	86 mm	72.5 mm
Rebate height	25 mm	25 mm	18.5 mm
Glass thickness	up to 53 mm	up to 53 mm	up to 49 mm
Glazing method	dry glazing with EPDM or neutral silicones		
Thermal insulation	32 mm omega-ribbed and/or hollowchamber-shaped fibreglass reinforced polyamide strips		

PERFORMANCES

ENERGY

Thermal Insulation ⁽¹⁾ EN 10077-2	Uf-value between 1.6 W/m ² K and 2.6 W/m ² K, depending on the frame/vent combination
---	---

COMFORT

Acoustic performance ⁽²⁾ EN ISO 140-3; EN ISO 717-1	Rw (C; Ctr) = 36 (-1; -4) dB / 42 (-2; -4) dB, depending on glazing type
---	--

Air tightness, max. test pressure ⁽³⁾ EN 1026; EN 12207	1 (150 Pa)	2 (300 Pa)	3 (600 Pa)	4 (600 Pa)						
Water tightness ⁽⁴⁾ EN 1027; EN 12208	1A (0 Pa)	2A (50 Pa)	3A (100 Pa)	4A (150 Pa)	5A (200 Pa)	6A (250 Pa)	7A (300 Pa)	8A (450 Pa)	9A (600 Pa)	E (900 Pa)
Wind load resistance, max. test pressure ⁽⁵⁾ EN 12211; EN 12210	1 (400 Pa)	2 (800 Pa)	3 (1200 Pa)	4 (1600 Pa)	5 (2000 Pa)	E _{xxx} (> 2000 Pa)				
Wind load resistance to frame deflection ⁽⁵⁾ EN 12211; EN 12210	A (≤1/150)		B (≤1/200)		C (≤1/300)					

SAFETY

Burglar resistance ⁽⁶⁾ ENV 1627 - ENV 1630	WK 1	WK 2	WK 3
--	------	------	------

This table shows possible classes and values of performances. The values indicated in red are the ones relevant to this system.

- (1) The Uf-value measures the heat flow. The lower the Uf-value, the better the thermal insulation of the frame.
- (2) The sound reduction index (Rw) measures the capacity of the sound reduction performance of the frame.
- (3) The air tightness test measures the volume of air that would pass through a closed window at a certain air pressure.
- (4) The water tightness testing involves applying a uniform water spray at increasing air pressure until water penetrates the window.
- (5) The wind load resistance is a measure of the profile's structural strength and is tested by applying increasing levels of air pressure to simulate the wind force. There are up to five levels of wind resistance (1 to 5) and three deflection classes (A,B,C). The higher the number, the better the performance.
- (6) The burglar resistance is tested by statistical and dynamic loads, as well as by simulated attempts to break in using specified tools.

