

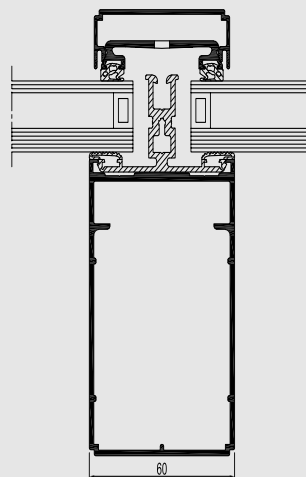

# CR 120

Conservatories

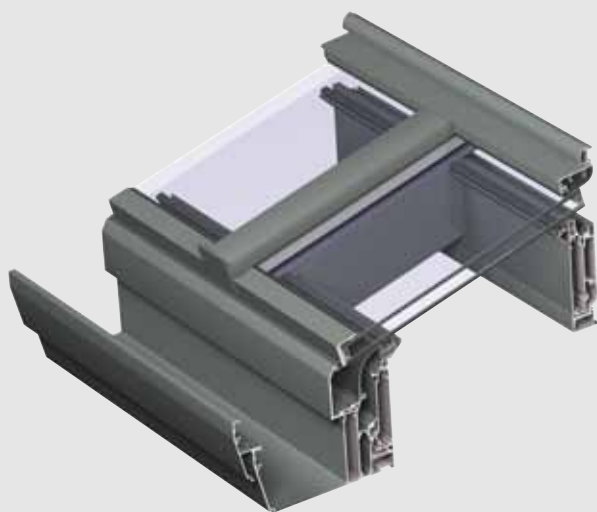

CR 120 is a thermally insulated conservatory roof system. The tubular aluminium rafters create space for integration of cabling and light on the inside while the small cover plates on the outside create a slim design.

This system is compatible with all Reynaers window and door systems as well as sliding systems and offers the possibility to create a wide range of conservatory constructions and skylights.

Compatibility with motorised attic windows and roller shutters take care of a safe and comfortable environment.

## TECHNICAL CHARACTERISTICS



**FUNCTIONAL**

**RENAISSANCE**

**ORANGERY**

Style variants	
Min. visible width of rafter	60 mm
System depth of rafter	70 mm / 100 mm / 120 mm / 150 mm
Slope	5° - 45°
Rooftop	90° - 170°
Glass thickness	From 6 mm to 40 mm
Glazing method	Dry glazing with EPDM or neutral silicones
Thermal insulation	Omega-shaped fiberglass reinforced polyamide strips + synthetic profile



## PERFORMANCES

### ENERGY

Thermal Insulation <sup>(1)</sup>  
EN ISO 10077-2

Specific calculation per profile combination  
please contact your Reynaers Aluminium fabricator

### COMFORT

Water tightness <sup>(2)</sup> EN 1027; EN 12208	1A (0 Pa)	2A (50 Pa)	3A (100 Pa)	4A (150 Pa)	5A (200 Pa)	6A (250 Pa)	7A (300 Pa)	8A (450 Pa)	9A (600 Pa)	E750 (750 Pa)
Wind load resistance, max. test pressure <sup>(3)</sup> , EN 12211; EN 12210	1 (400 Pa)	2 (800 Pa)	3 (1200 Pa)	4 (1600 Pa)	5 (2000 Pa)	Exxx (> 2000 Pa)				

This table shows possible classes and values of performances. The values indicated in red are the ones relevant to this system.

(1) The Uf-value measures the heat flow. The lower the Uf-value, the better the thermal insulation of the frame.

(2) The water tightness testing involves applying a uniform water spray at increasing air pressure until water penetrates the window.

(3) The wind load resistance is a measure of the profile's structural strength and is tested by applying increasing levels of air pressure to simulate the wind force. There are up to five levels of wind resistance (1 to 5) and three deflection classes (A,B,C). The higher the number, the better the performance.