

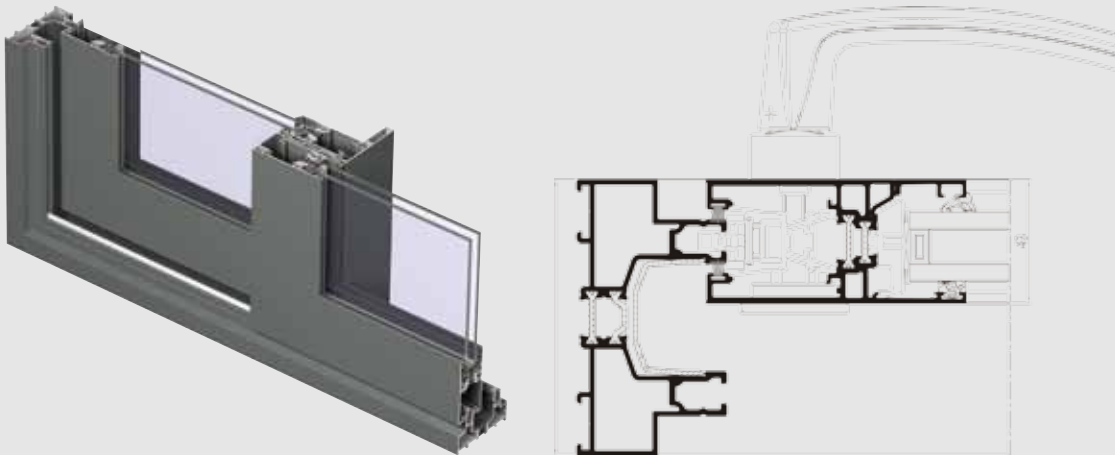

CP 96

Sliding Systems

R
REYNAERS
aluminium



The CP 96 sliding and lift & slide elements are the perfect answer to the increasing demand for safety and durability at a fair price. They are combined with strong technical performance to make up a highly innovative system. The CP 96-AP variant is also available in slide and lift & slide version and offers an enhanced burglary resistance.



TECHNICAL CHARACTERISTICS

Style variants	CP 96 MONORAIL	CP 96 2-RAIL	CP 96 3-RAIL	CP 96-LS 2-RAIL
Visible width / height				
Frame	52 mm	52 mm	52 mm	28 mm
Vent	90 mm	90 mm	90 mm	90 mm
T-profile	89 - 102 mm	89 - 102 mm	89 - 102 mm	89 - 102 mm
Meeting section	104 mm	104 mm	104 mm	104 mm
Overall system depth				
Frame	96 mm	96 mm	149 mm	96 mm
Vent	43 mm	43 mm	43 mm	43 mm
Rebate height	25 mm	25 mm	25 mm	25 mm
Glass thickness	11 - 30 mm	11 - 30 mm	11 - 30 mm	11 - 30 mm
Glazing method	dry glazing with EPDM or neutral silicones			
Thermal insulation	14 mm and 18.6 mm glass fibre reinforced polyamide strips	14 mm and 18.6 mm glass fibre reinforced polyamide strips	14 mm and 18.6 mm glass fibre reinforced polyamide strips	14 mm and 23 mm glass fibre reinforced polyamide strips

TECHNICAL CHARACTERISTICS

Style variants	CP 96-AP MONORAIL	CP 96-AP 2-RAIL	CP 96-AP 3-RAIL	CP 96-LS/AP 2-RAIL
Visible width / height				
Frame	52 mm	52 mm	52 mm	38 mm
Vent	100 mm	100 mm	100 mm	100 mm
T-profile	89 - 102 mm	89 - 102 mm	89 - 102 mm	89 - 102 mm
Meeting section	104 mm	104 mm	104 mm	104 mm
Overall system depth				
Frame	96 mm	96 mm	149 mm	96 mm
Vent	43 mm	43 mm	43 mm	43 mm
Rebate height	25 mm	25 mm	25 mm	25 mm
Glass thickness	11 - 30 mm	11 - 30 mm	11 - 30 mm	11 - 30 mm
Glazing method	dry glazing with EPDM or neutral silicones			
Thermal insulation	14 mm and 18.6 mm glass fibre reinforced polyamide strips	14 mm and 18.6 mm glass fibre reinforced polyamide strips	14 mm and 18.6 mm glass fibre reinforced polyamide strips	14 mm and 23 mm glass fibre reinforced polyamide strips



PERFORMANCES

ENERGY

Thermal Insulation⁽¹⁾
EN ISO 10077-2

Uf-value between 3.5 W/m²K and 6.3 W/m²K,
depending on the frame/vent combination.

COMFORT

Air tightness, max. test pressure⁽²⁾
EN 1026; EN 12207

1 (150 Pa)	2 (300 Pa)	3 (600 Pa)	4 (600 Pa)
---------------	---------------	---------------	---------------

Water tightness⁽³⁾
EN 1027; EN 12208

1A (0 Pa)	2A (50 Pa)	3A (100 Pa)	4A (150 Pa)	5A (200 Pa)	6A (250 Pa)	7A (300 Pa)	8A (450 Pa)	9A (600 Pa)	Exxx (>600 Pa)
--------------	---------------	----------------	----------------	----------------	----------------	----------------	----------------	----------------	-------------------

Wind load resistance, max. test pressure⁽⁴⁾
EN 12211; EN 12210

1 (400 Pa)	2 (800 Pa)	3 (1200 Pa)	4 (1600 Pa)	5 (2000 Pa)	Exxx (> 2000 Pa)
---------------	---------------	----------------	----------------	----------------	---------------------

Wind load resistance to frame deflection⁽⁴⁾
EN 12211; EN 12210

A (≤ 1/150)	B (≤ 1/200)	C (≤ 1/300)
----------------	----------------	----------------

SAFETY

Burglar resistance⁽⁵⁾
NEN 5096

WK 1	WK 2	WK 3
------	------	------

This table shows possible classes and values of performances. The values indicated in red are the ones relevant to this system.

- (1) The Uf-value measures the heat flow. The lower the Uf-value, the better the thermal insulation of the frame.
 (2) The air tightness test measures the volume of air that would pass through a closed window at a certain air pressure.
 (3) The water tightness testing involves applying a uniform water spray at increasing air pressure until water penetrates the window.
 (4) The wind load resistance is a measure of the profile's structural strength and is tested by applying increasing levels of air pressure to simulate the wind force.
 There are up to five levels of wind resistance (1 to 5) and three deflection classes (A,B,C). The higher the number, the better the performance.
 (5) The burglar resistance is tested by statistical and dynamic loads, as well as by simulated attempts to break in using specified tools.

REYNAERS ALUMINIUM NV/SA • www.reynaers.com • info@reynaers.com

06/2010 - 0H0.22C2.00 - Publisher Responsible at Law: A. de Cordes, Oude Liersebaan 266, B-2570 Duffel

