

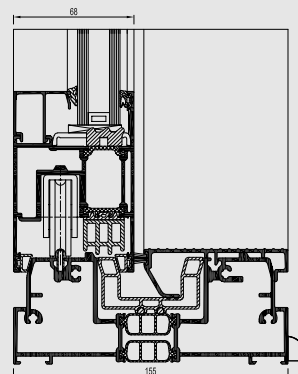

CP 155

Sliding System

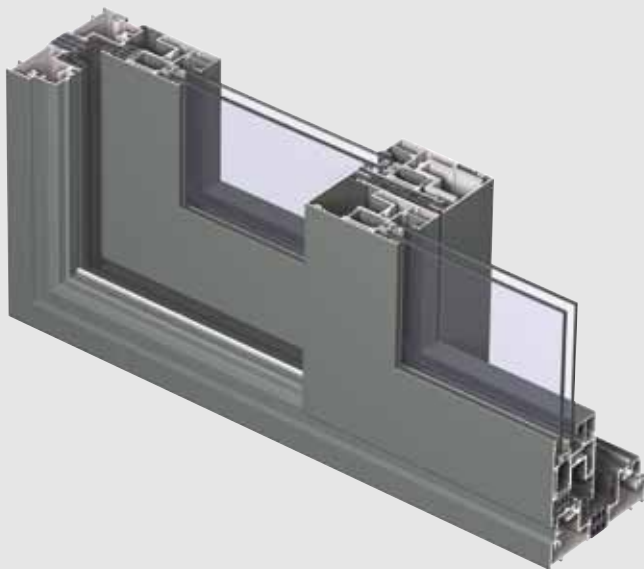

CP 155 is a thermally insulated sliding system with a vent weight up to 400 kg and height up to 3 metres. The sophisticated concept fulfils the user's high expectations of optimum quality, high insulation and ease of operation. The new and improved CP 155 can be upgraded with High Insulation that can be applied to all CP 155 variants to achieve even better insulation values.

The system is available with a low threshold that creates a perfect continuity between the indoor and outdoor spaces and improves the accessibility to the building. CP 155 is provided with an aesthetical middle section and can be applied for large spans. Automatic opening solutions for maximal comfort are also available.

TECHNICAL CHARACTERISTICS

Style variants

CP 155
MONORAIL / 2-RAIL / 3-RAIL
LS MONORAIL / LS 2-RAIL / LS 3-RAIL

Visible width / height	
Frame	60 mm
Vent	102 mm
T-profile	76-89-102-115-154 mm
Meeting section	115 mm
Threshold	60 mm / 20 mm
Overall system depth	
Frame	155 mm / 242 (3-rail / LS 3-rail)
Vent	68 mm
Rebate height	25 mm
Glass thickness	13 - 52 mm
Glazing method	dry glazing with EPDM or neutral silicones
Thermal insulation	23 mm and 32 mm fibreglass reinforced polyamide strips with 3 chambers
HI variant	extra insulating gaskets

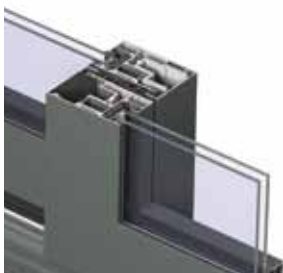

Slim Line middle section



low threshold



HI-variant

PERFORMANCES

ENERGY

Thermal Insulation⁽¹⁾
 EN ISO 10077-2

Uf-value up to 2.2 W/m²K (*),
 depending on the frame/vent combination.

COMFORT

Acoustic performance⁽²⁾
 EN ISO 140-3; EN ISO 717-1

Rw (C; Ctr) = 35 (-2;-5) dB / 42 (-1;-3) dB, depending on glazing type

Air tightness, max. test pressure⁽³⁾
 EN 12207

1 (150 Pa)	2 (300 Pa)	3 (600 Pa)	4 (600 Pa)
---------------	---------------	---------------	---------------

Water tightness⁽⁴⁾
 EN 12208

1A (0 Pa)	2A (50 Pa)	3A (100 Pa)	4A (150 Pa)	5A (200 Pa)	6A (250 Pa)	7A (300 Pa)	8A (450 Pa)	9A (600 Pa)	E900 (900 Pa)
--------------	---------------	----------------	----------------	----------------	----------------	----------------	----------------	----------------	------------------

Wind load resistance,
 max. test pressure⁽⁵⁾
 EN 12211; EN 12210

1 (400 Pa)	2 (800 Pa)	3 (1200 Pa)	4 (1600 Pa)	5 (2000 Pa)	Exxx (> 2000 Pa)
---------------	---------------	----------------	----------------	----------------	---------------------

Wind load resistance to frame
 deflection⁽⁵⁾
 EN 12211; EN 12210

A (≤1/150)	B (≤1/200)	C (≤1/300)
---------------	---------------	---------------

SAFETY

Burglar resistance⁽⁶⁾
 ENV 1627 - ENV 1630

WK 1	WK 2	WK 3
------	------	------

This table shows possible classes and values of performances. The values indicated in red are the ones relevant to this system.

- (1) The Uf-value measures the heat flow. The lower the Uf-value, the better the thermal insulation of the frame.
- (2) The sound reduction index (Rw) measures the capacity of the sound reduction performance of the frame.
- (3) The air tightness test measures the volume of air that would pass through a closed window at a certain air pressure.
- (4) The water tightness testing involves applying a uniform water spray at increasing air pressure until water penetrates the window.
- (5) The wind load resistance is a measure of the profile's structural strength and is tested by applying increasing levels of air pressure to simulate the wind force. There are up to five levels of wind resistance (1 to 5) and three deflection classes (A,B,C). The higher the number, the better the performance.
- (6) The burglar resistance is tested by statistical and dynamic loads, as well as by simulated attempts to break in using specified tools.

(*) Value with HI-upgrade

