

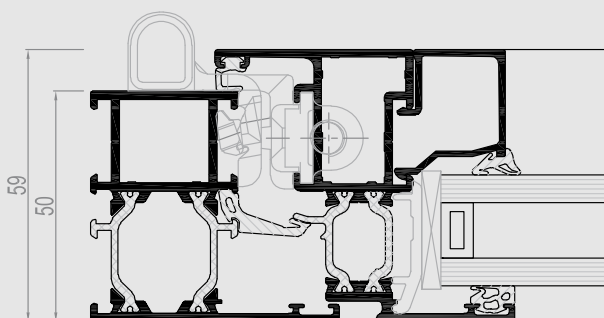

# Eco system

Windows & Doors

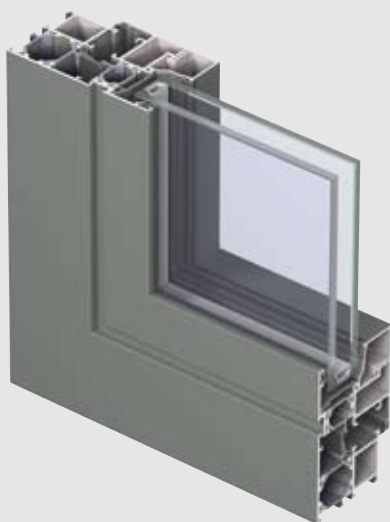

Eco system is a high performance aluminium system that combines aesthetic design with energy efficiency. With an Uf-value down to 2.25 W/m<sup>2</sup>K, this system meets the latest thermal insulation requirements.

Eco system offers a solution for every standard application for inward and outward opening windows, window-doors and flush doors. Furthermore, Eco system allows the fabrication, production and easy assembly of windows and doors in less time.

Different inner and outer colours are possible.

## TECHNICAL CHARACTERISTICS

Style variants	ECO SYSTEM	ECO SYSTEM UK VARIANT
Min. visible width inward opening window		
Frame	48 mm	-
Vent	30 mm	-
Min. visible width outward opening window		
Frame	21 mm	26.5mm
Vent	87 mm	73 mm
Min. visible width inward opening flush door		
Frame	67 mm	-
Vent	74 mm	-
Min. visible width outward opening flush door		
Frame	42 mm	-
Vent	99 mm	-
Min. visible width T-profile	70 mm	76 mm
Overall system depth window		
Frame	50 mm	50 mm
Vent	59 mm	50 mm
Overall system depth flush door		
Frame	50 mm	-
Vent	50 mm	-
Rebate height	22 mm	22 mm
Glass thickness	up to 32 mm	up to 32 mm
Glazing method	dry glazing with EPDM or neutral silicones	
Thermal insulation	omega-shaped fibreglass reinforced polyamide strips (frame 26.3 mm - vent 22 mm)	

## PERFORMANCES

### ENERGY

Thermal Insulation<sup>(1)</sup>  
EN 10077-2

Uf-value between 2.25 W/m<sup>2</sup>K and 2.55 W/m<sup>2</sup>K,  
depending on the frame/vent combination

### COMFORT

Acoustic performance<sup>(2)</sup>  
EN ISO 140-3; EN ISO 717-1

Rw (C; Ctr) = 35 (-1; -4) dB / 39 (-1; -3) dB, depending on glazing type

Air tightness, max. test pressure<sup>(3)</sup>  
EN 1026; EN 12207

1 (150 Pa)	2 (300 Pa)	3 (600 Pa)	4 (600 Pa)

Water tightness<sup>(4)</sup>  
EN 1027; EN 12208

1A (0 Pa)	2A (50 Pa)	3A (100 Pa)	4A (150 Pa)	5A (200 Pa)	6A (250 Pa)	7A (300 Pa)	8A (450 Pa)	9A (600 Pa)	E (750 Pa)

Wind load resistance,  
max. test pressure<sup>(5)</sup>  
EN 12211; EN 12210

1 (400 Pa)	2 (800 Pa)	3 (1200 Pa)	4 (1600 Pa)	5 (2000 Pa)	E <sub>xxx</sub> (> 2000 Pa)

Wind load resistance to frame  
deflection<sup>(5)</sup>  
EN 12211; EN 12210

A (≤1/150)	B (≤1/200)	C (≤1/300)

### SAFETY

Burglar resistance<sup>(6)</sup>  
ENV 1627 - ENV 1630

WK 1	WK 2 (windows & doors)	WK 3

This table shows possible classes and values of performances. The values indicated in red are the ones relevant to this system.

- (1) The Uf-value measures the heat flow. The lower the Uf-value, the better the thermal insulation of the frame.
- (2) The sound reduction index (Rw) measures the capacity of the sound reduction performance of the frame.
- (3) The air tightness test measures the volume of air that would pass through a closed window at a certain air pressure.
- (4) The water tightness testing involves applying a uniform water spray at increasing air pressure until water penetrates the window.
- (5) The wind load resistance is a measure of the profile's structural strength and is tested by applying increasing levels of air pressure to simulate the wind force. There are up to five levels of wind resistance (1 to 5) and three deflection classes (A,B,C). The higher the number, the better the performance.
- (6) The burglar resistance is tested by statistical and dynamic loads, as well as by simulated attempts to break in using specified tools.

