

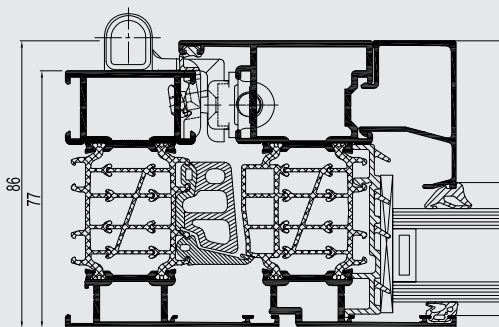

# CS 86-HI

Windows & Doors

**R**  
REYNAERS  
aluminium

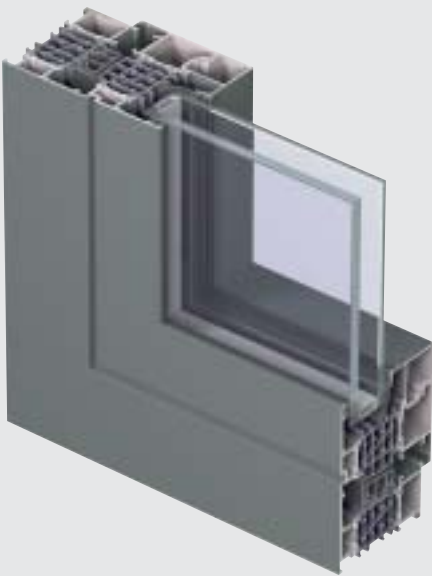

CS 86-HI is a multi-chamber system for windows and doors that combines aesthetic design, optimal stability and high thermal comfort. Due to the insulating skeleton strips, CS 86-HI achieves Uf-values down to 1.47 W/m<sup>2</sup>K, making this a highly energy efficient system. Flexible expansion strips in the door vents ensure stability in all conditions.

The system provides inside opening windows and inside & outside opening flush doors (up to 3 meters). Furthermore, CS 86-HI doors offer different types of floor connections to meet acoustic, thermal and water requirements.

## TECHNICAL CHARACTERISTICS



Style variants	FUNCTIONAL	HIDDEN VENT
Min. visible width inward opening window		
Frame	51 mm	70 mm
Vent	35 mm	not visible
Min. visible width inward opening flush door		
Frame	68 mm	-
Vent	76 mm	-
Min. visible width outward opening flush door		
Frame	42 mm	-
Vent	102 mm	-
Min. visible width T-profile	76 mm	95 mm
Overall system depth window		
Frame	77 mm	77 mm
Vent	86 mm	79 mm
Rebate height	25 mm	17 mm
Glass thickness	up to 63 mm	up to 44 mm
Glazing method	dry glazing with EPDM or neutral silicones	
Thermal insulation	41 mm fibreglass reinforced polyamide strips in skeleton structure or hollowchamber shape 32 mm (flexible) expansion strips	



## PERFORMANCES

### ENERGY

Thermal Insulation<sup>(1)</sup>  
EN 10077-2

Uf-value between 1.47 W/m<sup>2</sup>K and 1.9 W/m<sup>2</sup>K, depending on the frame/vent combination

### COMFORT

Acoustic performance<sup>(2)</sup>  
EN ISO 140-3; EN ISO 717-1

Rw (C; Ctr) = 36 (-1; -4) dB / 44 (0; -2) dB, depending on glazing type

Air tightness, max. test pressure<sup>(3)</sup>  
EN 1026; EN 12207

1 (150 Pa)	2 (300 Pa)	3 (600 Pa)	4 (600 Pa)

Water tightness<sup>(4)</sup>  
EN 1027; EN 12208

1A (0 Pa)	2A (50 Pa)	3A (100 Pa)	4A (150 Pa)	5A (200 Pa)	6A (250 Pa)	7A (300 Pa)	8A (450 Pa)	9A (600 Pa)	E (900 Pa)

Wind load resistance, max. test pressure<sup>(5)</sup>  
EN 12211; EN 12210

1 (400 Pa)	2 (800 Pa)	3 (1200 Pa)	4 (1600 Pa)	5 (2000 Pa)	E <sub>xxx</sub> (> 2000 Pa)

Wind load resistance to frame deflection<sup>(5)</sup>  
EN 12211; EN 12210

A (≤1/150)	B (≤1/200)	C (≤1/300)

### SAFETY

Burglar resistance<sup>(6)</sup>  
ENV 1627 - ENV 1630

WK 1	WK 2 (windows & doors)	WK 3

This table shows possible classes and values of performances. The values indicated in red are the ones relevant to this system.

- (1) The Uf-value measures the heat flow. The lower the Uf-value, the better the thermal insulation of the frame.
- (2) The sound reduction index (Rw) measures the capacity of the sound reduction performance of the frame.
- (3) The air tightness test measures the volume of air that would pass through a closed window at a certain air pressure.
- (4) The water tightness testing involves applying a uniform water spray at increasing air pressure until water penetrates the window.
- (5) The wind load resistance is a measure of the profile's structural strength and is tested by applying increasing levels of air pressure to simulate the wind force. There are up to five levels of wind resistance (1 to 5) and three deflection classes (A,B,C). The higher the number, the better the performance.
- (6) The burglar resistance is tested by statistical and dynamic loads, as well as by simulated attempts to break in using specified tools.

