

set scharen set compas Satz Klappschere set friction stays	060.8280.-- (16mm)		
	FB(min)	FB(max)	FG(max)
060.8280.--	400	700	24kg

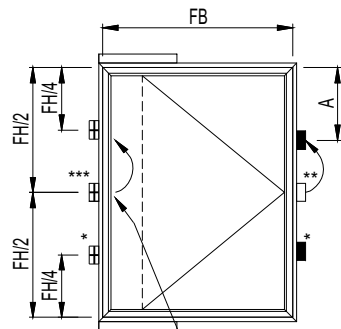

- RAAMPOMP
CREMONE
HANDHEBEL
HANDLE
- RAAM MET 2 RAAMPOMPEN
FENETRE AVEC 2 CREMONES
FENSTER MIT 2 HANDHEBEL
WINDOW WITH 2 HANDLES
- ▣ SLUITSTUK
GACHE
SCHLIESSTÜCK
LOCK PLATE
- ▭ UITZETSCHAREN
COMPAS
SCHEREN
FRICTION STAYS

A min= FH/5
A max= FH/3

- *SUPPLEMENTAIR BESLAG
*ACCESSOIRES SUPPLEMENTAIRES
*ZUSATZBESCHLAG
*SUPPLEMENTARY ACCESSORIES
- **VERPLAATSEN BIJ EXTRA RAAMPOMP
**DEPLACER EN CAS DE CREMONE SUPPLEMENTAIRE
**UMSTELLEN BEI ZUSAETZLICHEM HANDHEBEL
**MOVE IN CASE OF ADDITIONAL HANDLE
- ***VERPLAATSEN BIJ EXTRA SLUITSTUK
***DEPLACER EN CAS DE GACHE SUPPLEMENTAIRE
***UMSTELLEN BEI ZUSAETZLICHEM SCHLIESSTÜCK
***MOVE IN CASE OF ADDITIONAL LOCK PLATE

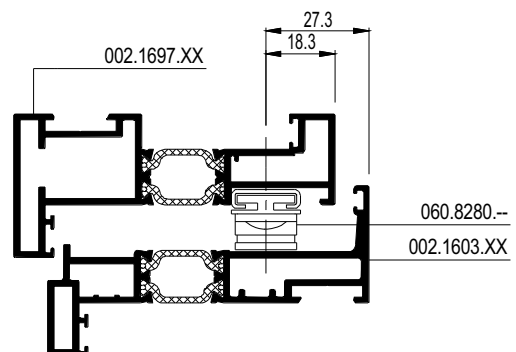
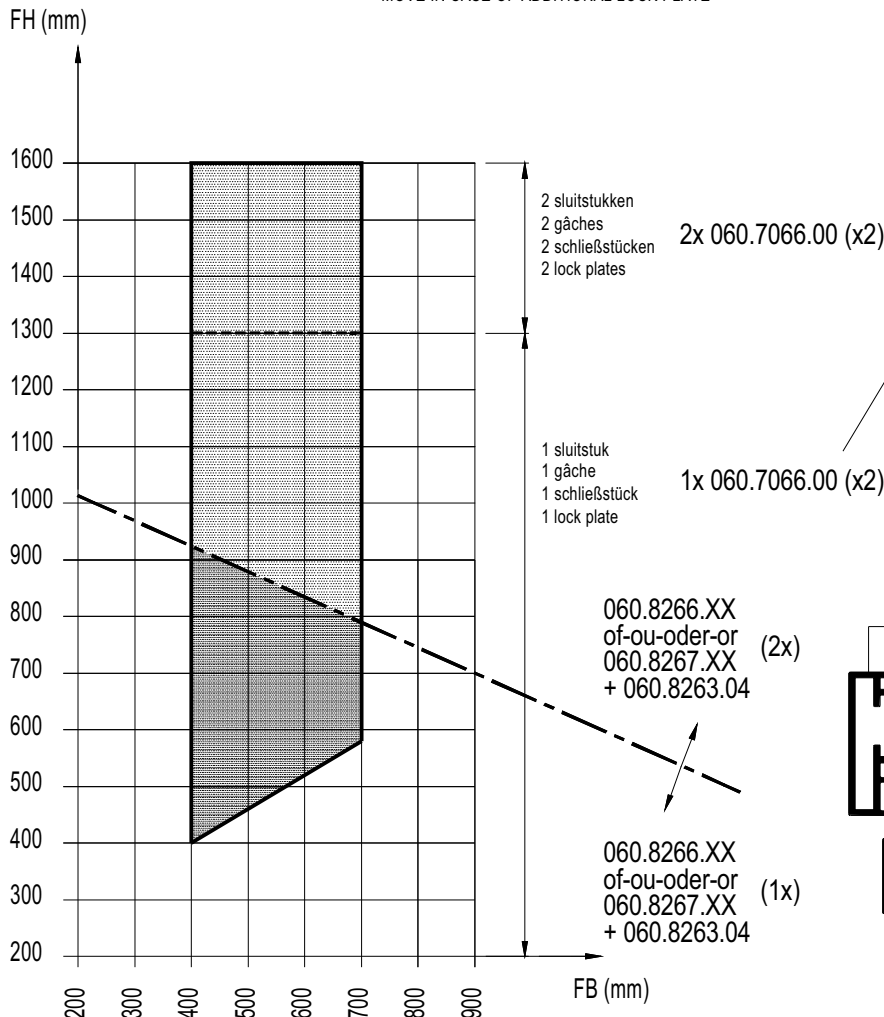

	FH(min)	FH(max)	FG(max)
060.8281.--	200	350	12kg
060.8282.--	275	400	16kg
060.8283.--	350	550	20kg
060.8284.--	500	780	21kg
060.8285.--	700	1100	26kg
060.8286.--	850	1300	40kg
060.8287.--	1090	1500	100kg

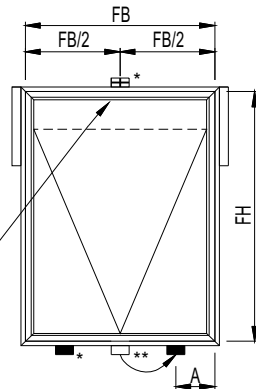

- RAAM MET 1 RAAMPOMP
FENETRE AVEC 1 CREMONE
FENSTER MIT 1 HANDHEBEL
WINDOW WITH 1 HANDLE
- RAAM MET 2 RAAMPOMPEN
FENETRE AVEC 2 CREMONES
FENSTER MIT 2 HANDHEBEL
WINDOW WITH 2 HANDLES
- ⊞ SLUITSTUK
GACHE
SCHLIESSTUCK
LOCK PLATE
- ⊞ UITZETZSCHAREN
COMPAS
SCHEREN
FRICTION STAYS

A min= FB/5
 A max= FB/3

- *SUPPLEMENTAIR BESLAG
*ACCESSOIRES SUPPLEMENTAIRES
*ZUSATZBESCHLAG
*SUPPLEMENTARY ACCESSORIES
- **VERPLAATSEN BIJ EXTRA RAAMPOMP
**DEPLACER EN CAS DE CREMONE SUPPLEMENTAIRE
**UMSTELLEN BEI ZUSAETZLICHEM HANDHEBEL
**MOVE IN CASE OF ADDITIONAL HANDLE

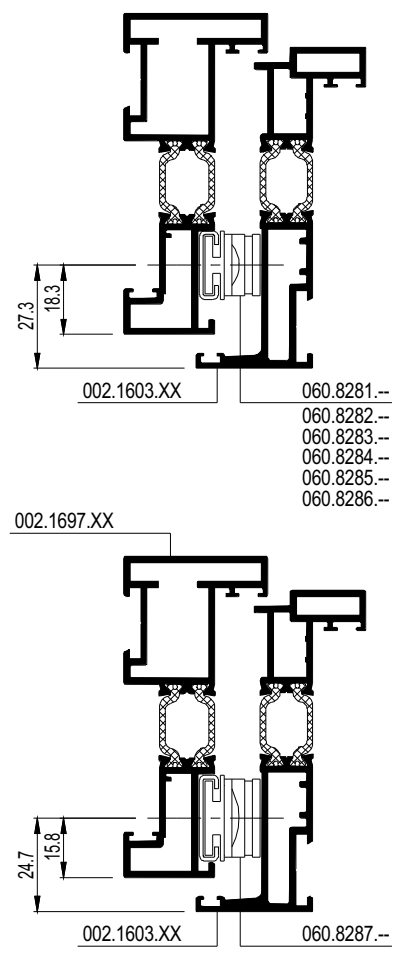
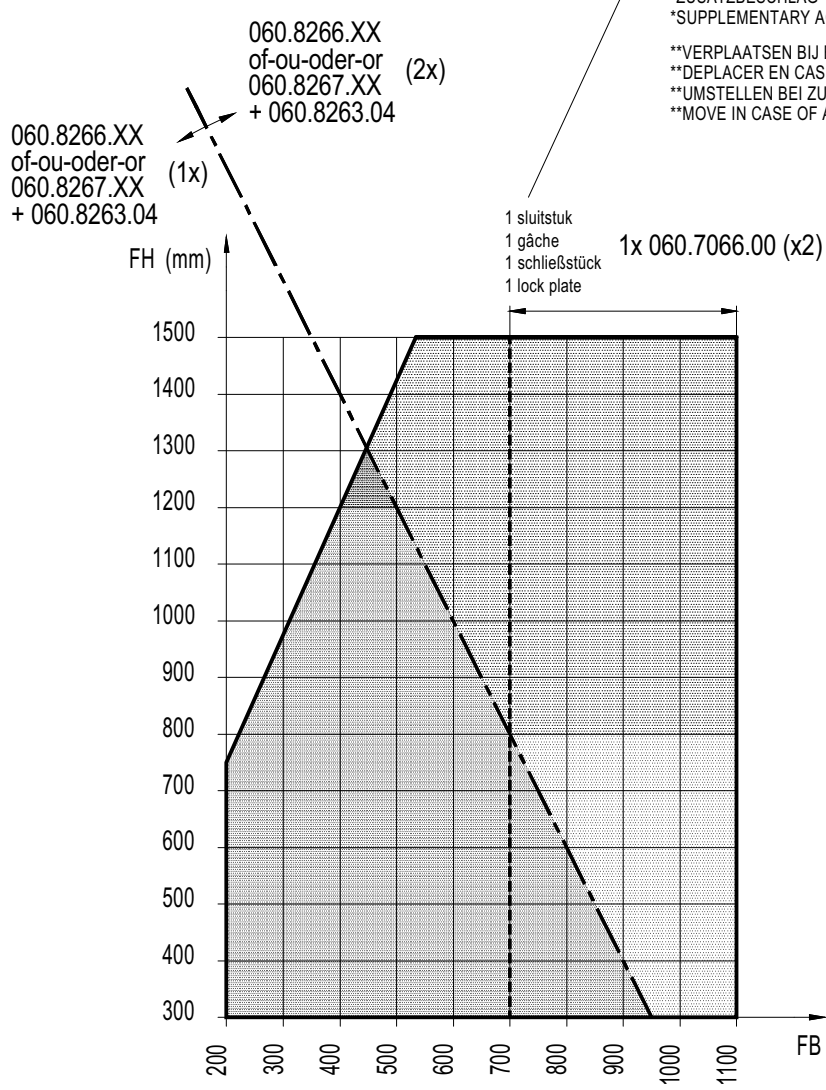

set scharen set compas Satz Klappschere set friction stays	060.829(X).-- (13mm)		
	FB(min)	FB(max)	FG(max)
060.8298.--	300	600	22kg
060.8299.--	400	700	24kg

Ramen met scharen 13mm hebben een beperkte openingshoek van 40°
 Fenêtres avec compas 13mm ont une angle d'ouverture limité de 40°
 Windows with friction stays 13mm have a restricted opening angle of 40°
 Fenster mit schere 13mm haben ein limitierte Öffnungswinkel von 40°

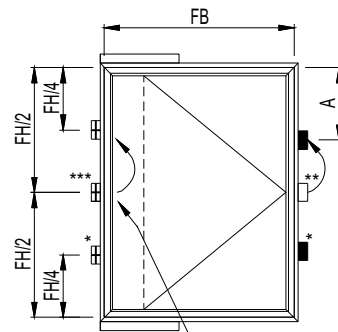

- RAAMPOMP
CREMONE
HANDHEBEL
HANDLE
- RAAM MET 2 RAAMPOMPEN
FENETRE AVEC 2 CREMONES
FENSTER MIT 2 HANDHEBEL
WINDOW WITH 2 HANDLES
- ▤ SLUITSTUK
GACHE
SCHLIESSTUCK
LOCK PLATE
- ▨ UITZETSCHAREN
COMPAS
SCHEREN
FRICTION STAYS

A min= FH/5
 A max= FH/3

*SUPPLEMENTAIR BESLAG
 *ACCESSOIRES SUPPLEMENTAIRES
 *ZUSATZBESCHLAG
 *SUPPLEMENTARY ACCESSORIES

**VERPLAATSEN BIJ EXTRA RAAMPOMP
 **DEPLACER EN CAS DE CREMONE SUPPLEMENTAIRE
 **UMSTELLEN BEI ZUSAETZLICHEM HANDHEBEL
 **MOVE IN CASE OF ADDITIONAL HANDLE

***VERPLAATSEN BIJ EXTRA SLUITSTUK
 ***DEPLACER EN CAS DE GACHE SUPPLEMENTAIRE
 ***UMSTELLEN BEI ZUSAETZLICHEM SCHLIESSTUCK
 ***MOVE IN CASE OF ADDITIONAL LOCK PLATE

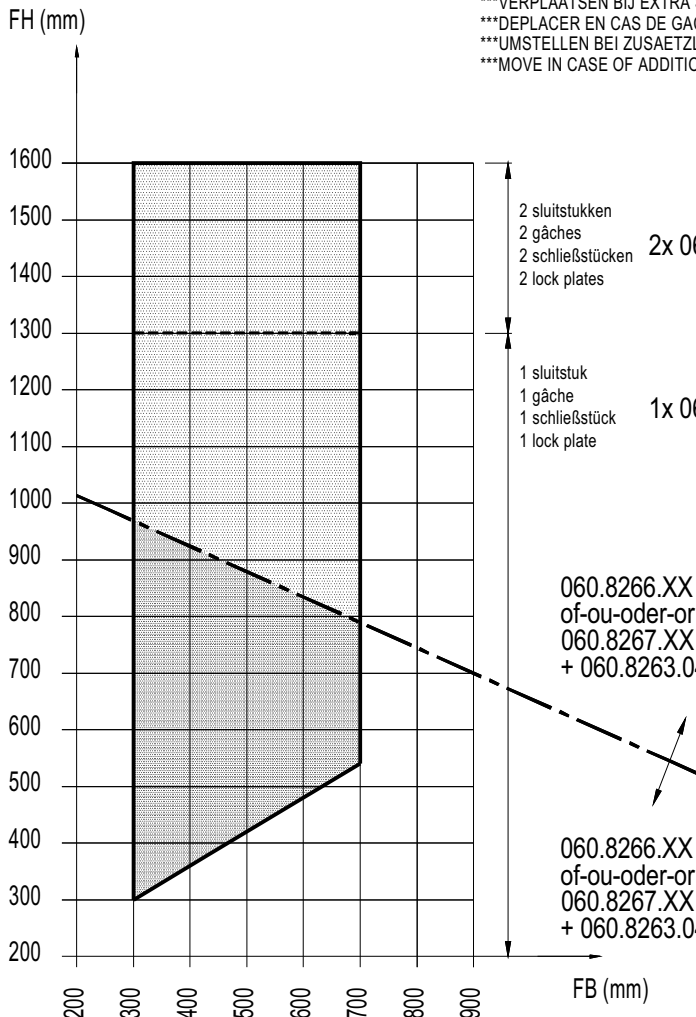

2 sluitstukken
 2 gâches
 2 schließstücken
 2 lock plates
 2x 060.7066.00 (x2)

1 sluitstuk
 1 gâche
 1 schließstück
 1 lock plate
 1x 060.7066.00 (x2)

060.8266.XX
 of-ou-oder-or
 060.8267.XX
 + 060.8263.04

060.8266.XX
 of-ou-oder-or
 060.8267.XX
 + 060.8263.04
 (1x)

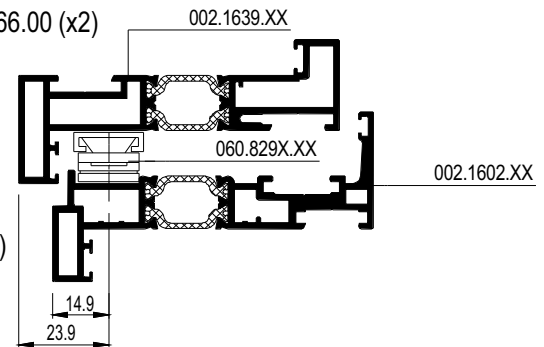

set scharen set compas Satz Klappschere set friction stays	060.829(X).-- (13mm)		
	FH(min)	FH(max)	FG(max)
060.8293.--	275	400	16kg
060.8294.--	350	550	20kg
060.8295.--	500	780	21kg
060.8296.--	700	1100	26kg
060.8297.--	850	1300	40kg

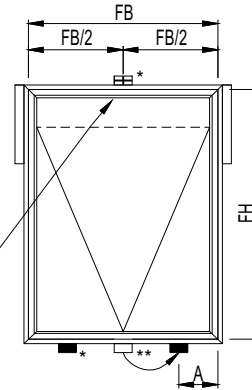

- RAAM MET 1 RAAMPOMP
FENETRE AVEC 1 CREMONE
FENSTER MIT 1 HANDHEBEL
WINDOW WITH 1 HANDLE
- RAAM MET 2 RAAMPOMPEN
FENETRE AVEC 2 CREMONES
FENSTER MIT 2 HANDHEBEL
WINDOW WITH 2 HANDLES
- ⊞ SLUITSTUK
GACHE
SCHLIESSTÜCK
LOCK PLATE
- ▤ UITZETSCHAREN
COMPAS
SCHEREN
FRICTION STAYS

$A_{min} = FB/5$
 $A_{max} = FB/3$

Ramen met scharen 13mm hebben een beperkte openingshoek van 40°
Fenêtres avec compas 13mm ont une angle d'ouverture limité de 40°
Windows with friction stays 13mm have a restricted opening angle of 40°
Fenster mit schere 13mm haben ein limitierte Öffnungswinkel von 40°

- *SUPPLEMENTAIR BESLAG
- *ACCESSOIRES SUPPLEMENTAIRES
- *ZUSATZBESCHLAG
- *SUPPLEMENTARY ACCESSORIES
- **VERPLAATSEN BIJ EXTRA RAAMPOMP
- **DEPLACER EN CAS DE CREMONE SUPPLEMENTAIRE
- **UMSTELLEN BEI ZUSÄTZLICHEM HANDHEBEL
- **MOVE IN CASE OF ADDITIONAL HANDLE

060.8266.XX
of-ou-oder-or
060.8267.XX
+ 060.8263.04 (1x)

060.8266.XX
of-ou-oder-or
060.8267.XX
+ 060.8263.04 (2x)

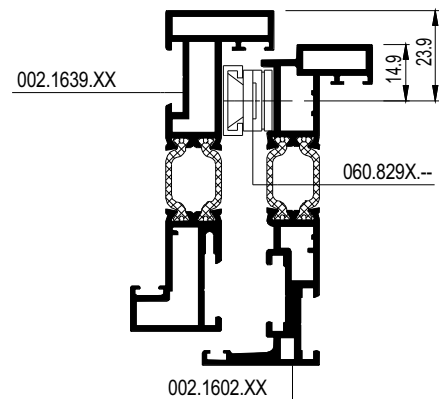
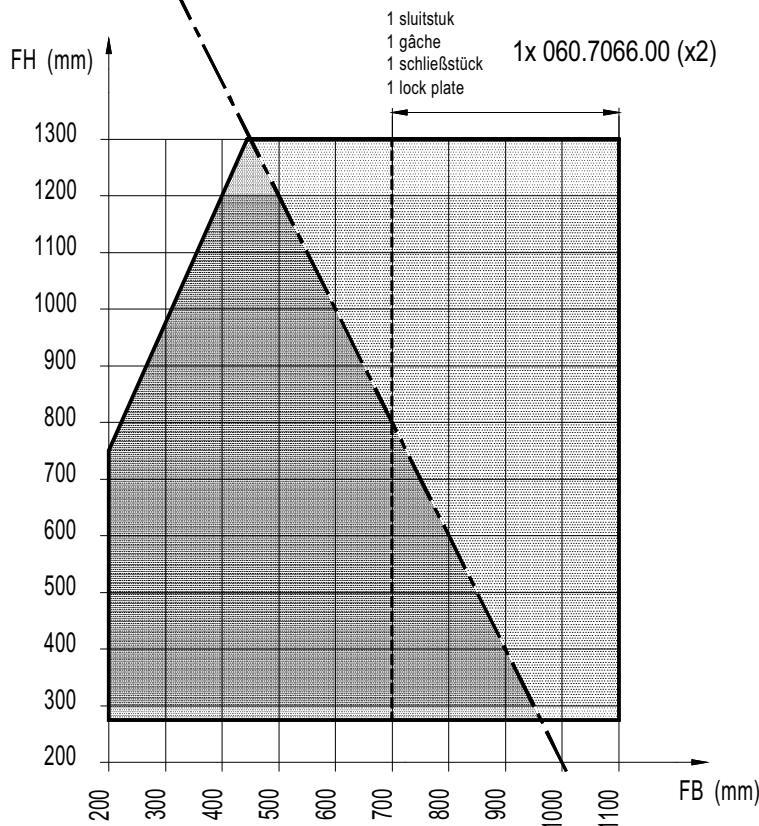

CS 24-SL

SCHAREN VOOR DRAAISCHUIFFRAAM
 COMPAS POUR OUVRANT PROJÉTANT
 FRICTION STAYS FOR SIDE-HUNG WINDOW
 AUSSTELLSCHEREN FUER DREHSCHIEBEFENSTER

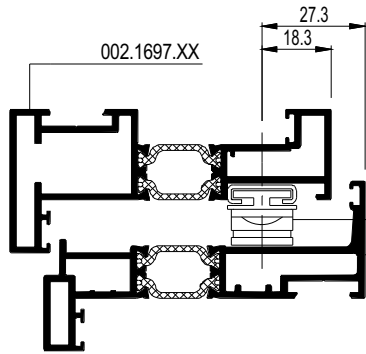
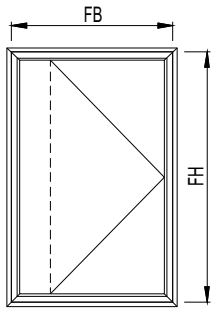

set scharen set compas Satz Klappschere set friction stays	FB(min)	FB(max)	FG(max)	afmetingen dimensions Abmessungen sizes
060.8280.--	400	700	24kg	412mm/16mm

060.8280.--
002.1603.XX

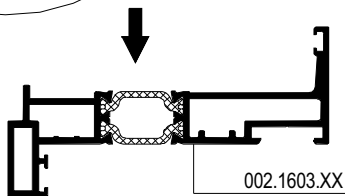
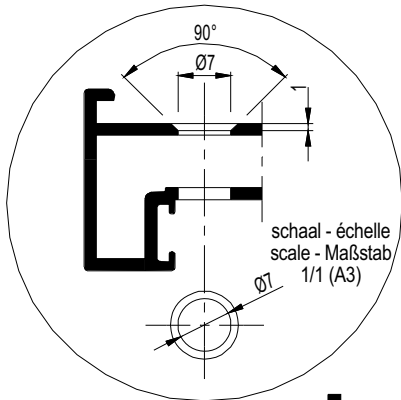
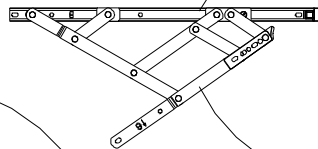
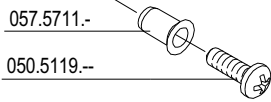
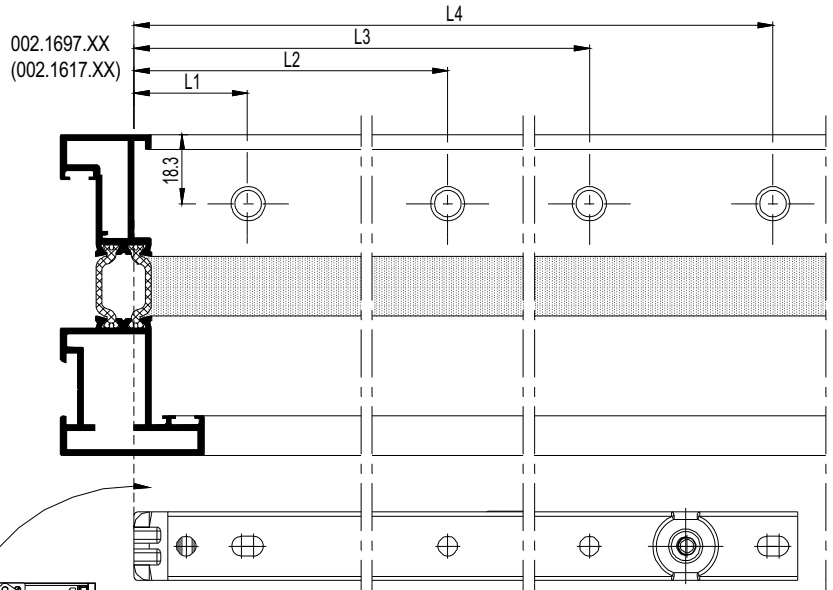
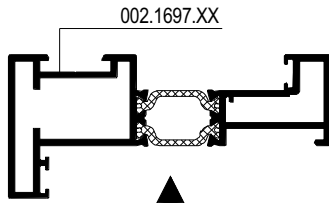

002.1603.XX

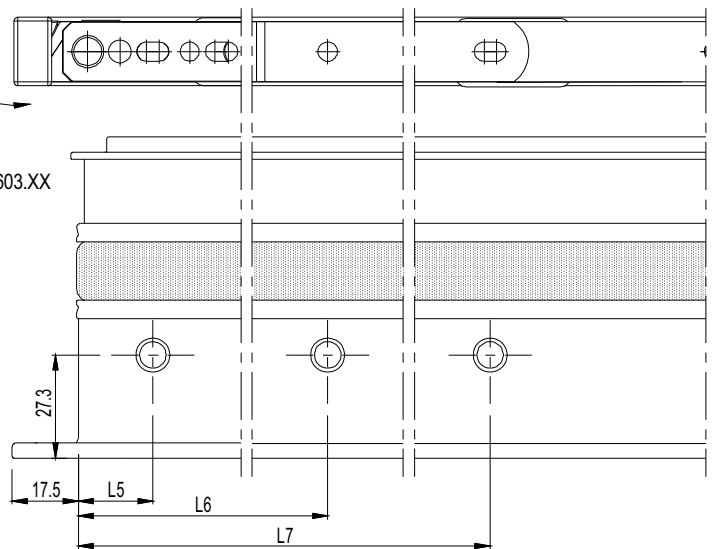

set scharen set compas Satz Klappschere set friction stays	L1	L2	L3	L4	L5	L6	L7
060.8280.--	30	239.5	357	405.5	20	172.5	240

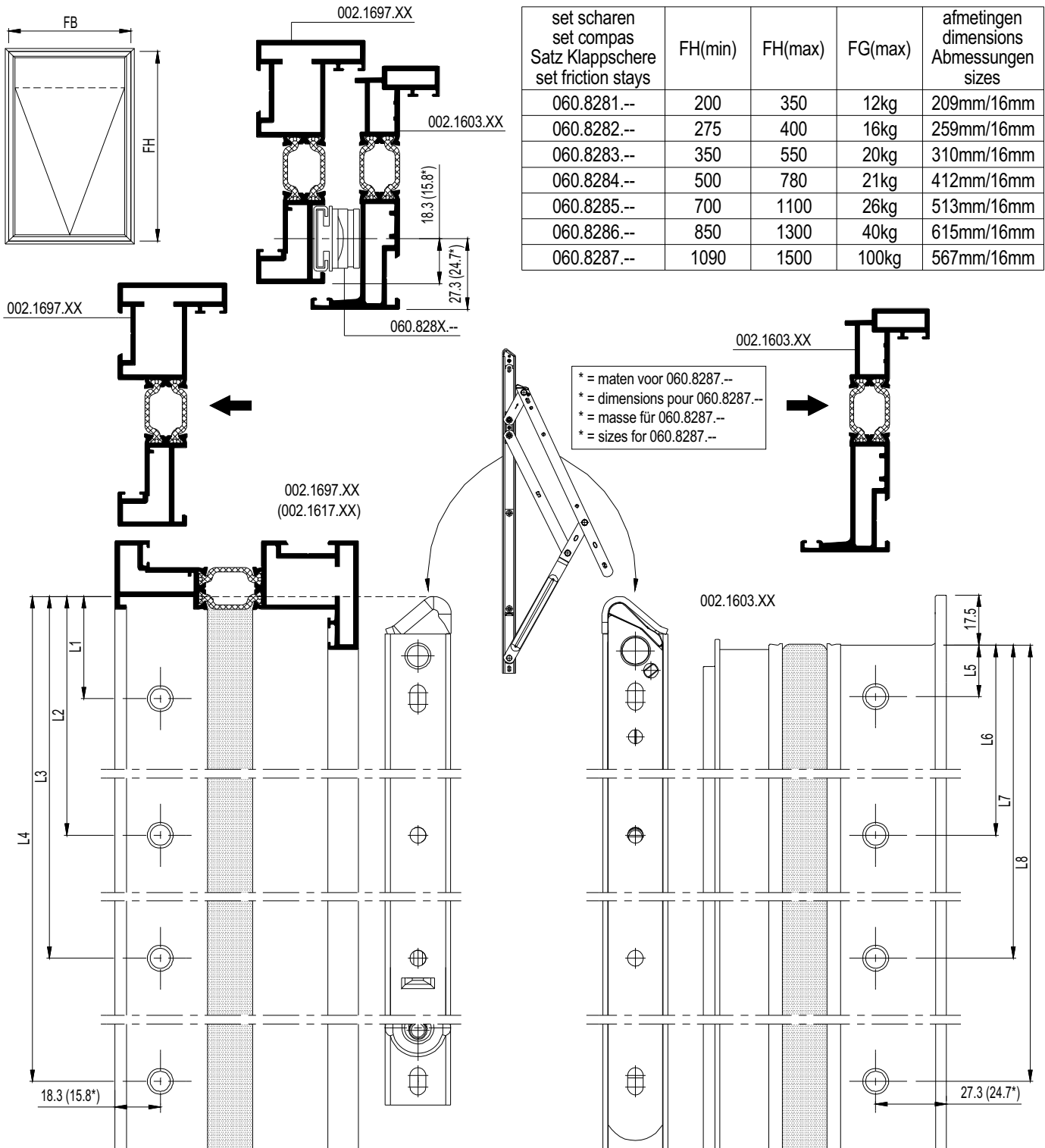

set scharen set compas Satz Klappschere set friction stays	L1	L2	L3	L4	L5	L6	L7	L8
060.8281.--	30	171	202.5		20	38	115	
060.8282.--	30	210	253		20	38	139.5	
060.8283.--	30	239.5	304		20	115	172.5	
060.8284.--	30	311	405.5		20	172.5	240.5	
060.8285.--	30	277	507		20	240.5	291.5	
060.8286.--	30	225	609		20	291.5	342.5	
(*) 060.8287.--	35.5	287	454	558.5	18	83	221	335.5

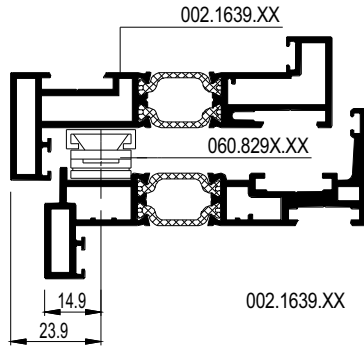
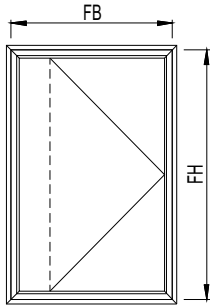

set scharen set compas Satz Klappschere set friction stays	FB(min)	FB(max)	FG(max)	afmetingen dimensions abmessungen sizes
060.8298.--	300	600	22kg	310mm/13mm
060.8299.--	400	700	24kg	412mm/13mm

Ramen met scharen 13mm hebben een beperkte openingshoek van 40°
 Fenêtres avec compas 13mm ont une angle d'ouverture limité de 40°
 Windows with friction stays 13mm have a restricted opening angle of 40°
 Fenster mit schere 13mm haben ein limitierte Öffnungswinkel von 40°

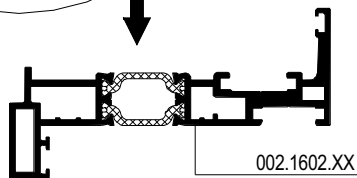
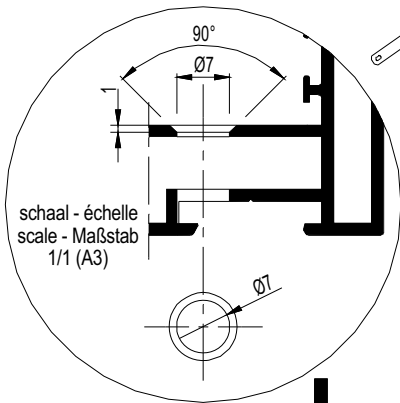
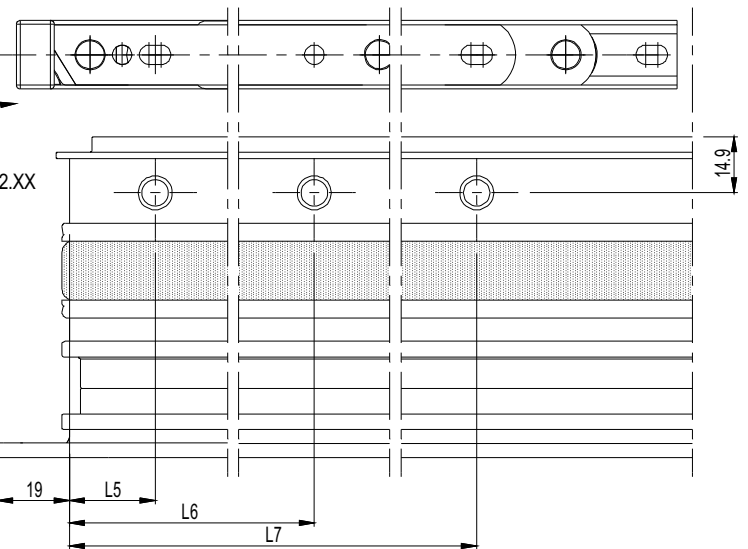
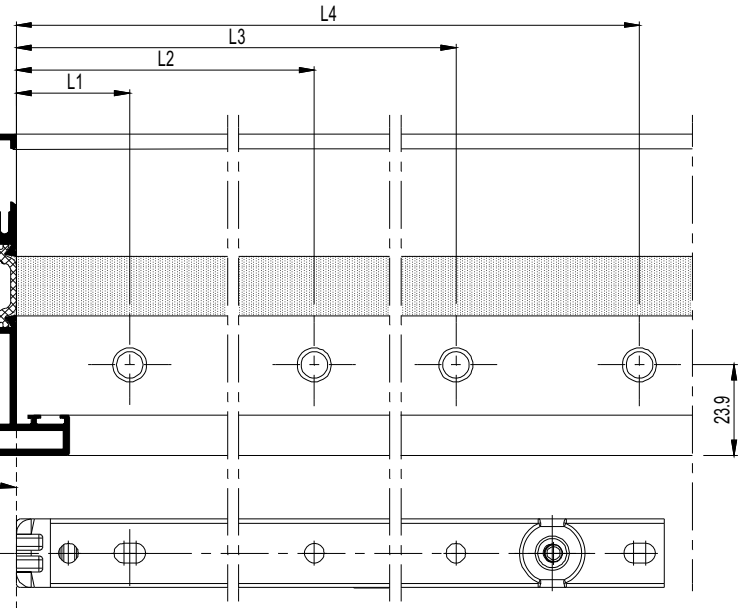
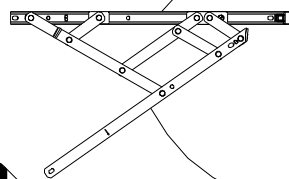
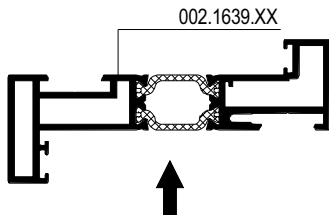
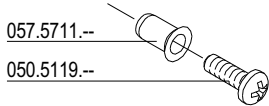

set scharen set compas Satz Klappschere set friction stays	L1	L2	L3	L4	L5	L6	L7
060.8298.--	30	225	304	23	253.5	268	
060.8299.--	30	239.5	357	405.5	23	129	345.5

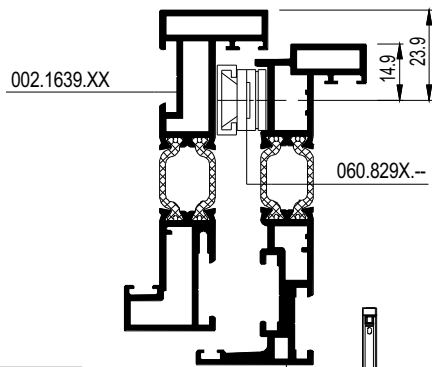
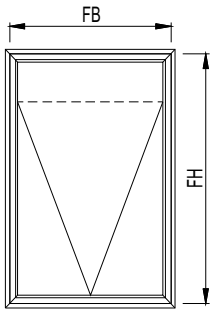

set scharen set compas Satz Klappschere set friction stays	FH(min)	FH(max)	FG(max)	afmetingen dimensions abmessungen sizes
060.8293.--	275	400	16kg	259mm/13mm
060.8294.--	350	550	20kg	310mm/13mm
060.8295.--	500	780	21kg	412mm/13mm
060.8296.--	700	1100	26kg	513mm/13mm
060.8297.--	850	1300	40kg	615mm/13mm

Ramen met scharen 13mm hebben een beperkte openingshoek van 40°
 Fenêtres avec compas 13mm ont une angle d'ouverture limité de 40°
 Windows with friction stays 13mm have a restricted opening angle of 40°
 Fenster mit schere 13mm haben ein limitierte Öffnungswinkel von 40°

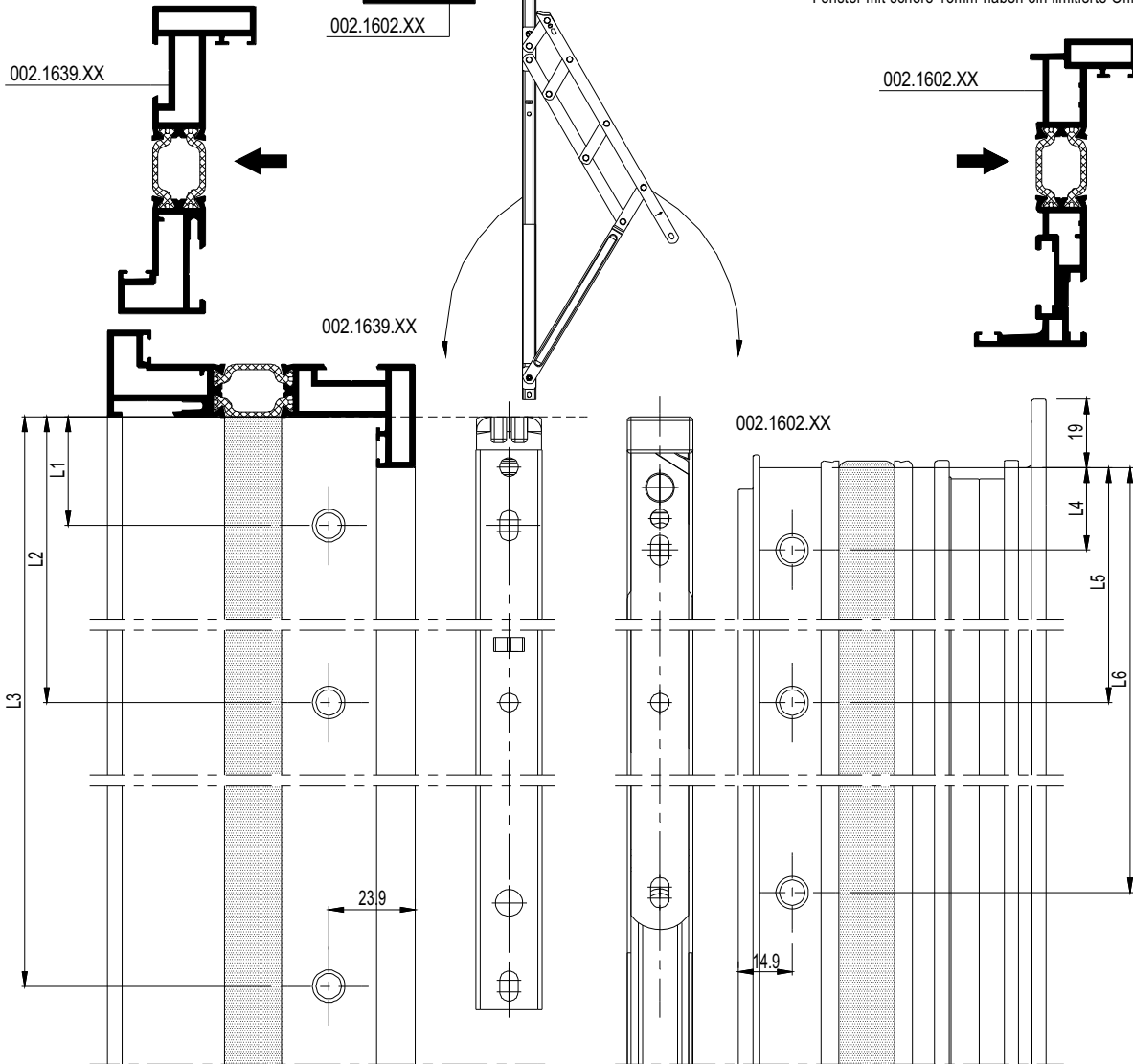

set scharen set compas Satz Klappschere set friction stays	L1	L2	L3	L4	L5	L6
060.8293.--	30	210	253	23	55	175.5
060.8294.--	30	239.5	304	23	70	211
060.8295.--	30	311	405.5	23	129	251.5
060.8296.--	30	277	507	23	193.5	294.5
060.8297.--	30	225	609	23	243.5	345.5