

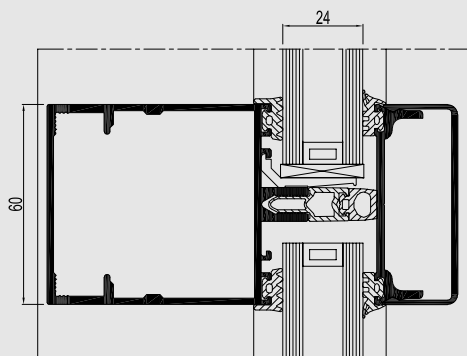

# CW 60

Solution for heavy glass panes

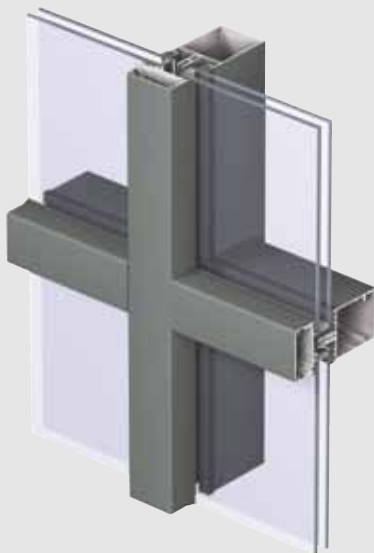

CW 60 is an excellent thermally improved curtain wall system for large glass surfaces (cassettes can hold a weight up to 450 kg per glass panel), sloping and vertical or curved constructions, especially for renovation projects.

The glazing is secured by clamp guides on the supporting construction and is held gripped under a rebate height of 25 mm. CW 60 is made up of an extensive profile range and facilitates the integration of all types of vent systems. The updated CW 60 offers four individual styles which each allow for the application of various outside appearances.







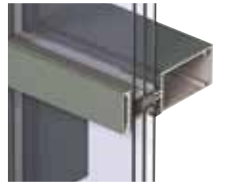



## TECHNICAL CHARACTERISTICS

			
Style variants	<b>CW 60</b> functional	<b>CW 60-HI</b> ultimate thermal comfort	<b>CW 60-SC</b> structural clamped glazing
Inside visible width	60 mm	60 mm	60 mm
Outside visible width	60 mm	60 mm	silicon joint or EPDM gasket of 20mm width
Depth mullions	from 79 to 268 mm	from 79 to 268 mm	from 79 to 268 mm
Depth transoms	from 78.4 to 204.4 mm	from 78.4 to 204.4 mm	from 78.4 to 204.4 mm
Glass thickness	6 to 62 mm	22 to 62 mm	27 to 63 mm
Types of vents	all Reynaers systems THW and POW (glass from 24 to 32 mm)	all Reynaers systems vents of CS 77 and CS 86-HI preferred	all Reynaers systems THW and POW (glass from 27 to 34 mm)

## TECHNICAL CHARACTERISTICS

			
Style variants	<b>CW 60-SG</b> structural sealed glazing	<b>CW 60-HL</b> functional	<b>CW 60-RA</b>
Inside visible width	60/88 mm	60 mm	60 mm
Outside visible width	EPDM gasket of 27mm width	vertical : 30 mm joint horizontal : 60 mm pressure plate	60 mm
Depth mullions	from 79 to 268 mm	from 79 to 268 mm	from 79 to 268 mm
Depth transoms	from 78.4 to 204.4 mm	from 78.4 to 204.4 mm	from 78.4 to 204.4 mm
Glass thickness	24 to 36 mm	22 to 48 mm	6 to 45 mm
Types of vents	not applicable	not applicable	flush roof vent

## PERFORMANCES

	<b>ENERGY</b>	
	Thermal insulation <sup>(1)</sup> EN 13947	Specific test per profile combination, please contact your Reynaers Aluminium fabricator
	<b>COMFORT</b>	
	Acoustic performance <sup>(2)</sup> EN ISO 140-3; EN ISO 717-1	Rw (C;Ctr) = 34 (-1;-4) dB/47 (-2;-5) dB, depending on the glazing type
	Air tightness, max. test pressure <sup>(3)</sup> EN 12153; EN 12152	A4 (600 Pa)
	Water tightness <sup>(4)</sup> EN 12155; EN 12154	R4 150   R5 300   R6 450   R7 600   RE 1200
	Wind load resistance, max. test pressure <sup>(5)</sup> EN 12179; EN 13116	2400 Pa
	Resistance against impact EN 14019	E5 / I5

This table shows possible classes and values of performances. The values indicated in red are the ones relevant to this system.

- (1) The Uf-value measures the heat flow. The lower the Uf-value, the better the thermal insulation of the frame.
- (2) The sound reduction index (Rw) measures the capacity of the sound reduction performance of the frame.
- (3) The air tightness test measures the volume of air that would pass through a closed window at a certain air pressure.
- (4) The water tightness testing involves applying a uniform water spray at increasing air pressure until water penetrates the window.
- (5) The wind load resistance is a measure of the profile's structural strength and is tested by applying increasing levels of air pressure to simulate the wind force. There are up to five levels of wind resistance (1 to 5) and three deflection classes (A,B,C). The higher the number, the better the performance.

